

AC/DC Solid State Power Controller Module

Description:

The Solid State Power Controller (SSPC) Module is a microcontroller based Solid State Relay designed to be used in Aircraft or Navy in 115VAC/150VDC applications. This module has integrated current sensing and over current / over temp protection. The module is equivalent to a DPST relay with a common single side isolated control.

Compliant Documents & Standards:

| | | |
|-------------------|--|----------------------|
| MIL-STD-167-1 (1) | Mechanical Vibrations of Shipboard Equipment | 19 June 1987 |
| MIL-STD-217F | Reliability Prediction of Electronic Equipment | Notice 2 28 Feb 1995 |
| P4855-1A | Navy Power Supply Design and Reliability Guidelines (NAVMAT) | January 1989 |



Module Features:

- Epoxy shell construction
- Solid state reliability; Low weight (60 gms)
- High power density
- Similar footprint as a mechanical relay: 2.8"x1.15"x1.15"
- Single-in-line pins to ease pcb assembly

Electrical Features:

- 115VAC Input: Current rating of 8A with very low drop; 180mV typ
- Current rating upto 12A with drop @ 280mV
- Advanced TRUE I²t algorithm to compensate for different current waveforms
- 2-Pole operation: 500V DC isolation between poles
- High control circuit isolation: 1500V DC to either pole
- Cross-trip feature: Fault on one pole trips the other within 50 μsec
- Very low control current: 14 mA typ @ 24V
- True I²t Protection from 12A to 90A
- Instant Trip Protection (3 μsec typ) for loads over 100A
- High Overload Capability up to 250A; Repetitive Fault handling capability
- Built-in Transient Voltage Suppressor to handle Short Circuit Turn-Off Spikes
- Over-temperature Protection: 75 °C Amb typ
- Internally generated isolated supply to drive the switch
- Opto Isolated Control Signal input and Status output
- Soft Turn-on to reduce EMC issues
- Module Reset with a Low Level Signal; Trip Reset Circuit is Trip-Free
- Built-in Hysteresis and Noise Filtering to avoid nuisance Turn-ON/OFF

Datasheet 4119, Rev. C.1

Electrical Characteristics

| Control & Status | |
|---------------------------------|--|
| Vcc | 24V DC Nominal 20V to 36V DC |
| Control Vcc Current (from +24V) | 14 mA typ 20 mA max |
| Alarm Out Signal | ON: High (internal pull-up to +24V); Output can source upto 5 mA OFF: Logic Low Output shall remain below 2V sink upto 5 mA |
| Control signal | ON: Logic Low (internal pull-up to +24V) Turns ON when input is pulled below 4V Input current @ Control pin < 0.5 mA OFF: Open Turns OFF when input is float or pulled above 12V |
| Reset | Thro cycling of Control signal Thro cycling of Vcc |

| Power | |
|--|---|
| Input Voltage | 0 to 170V DC 0 to 120V AC 10 Hz to 440 Hz |
| Power Dissipation | < 2.5W @ 8A @ 70°C Amb per pole |
| Current (Pole #1 and Pole #2) | 8A Continuous 250A for 3 μsec |
| Max Voltage Drop (Each Pole) | 180 mV typ @ 8A, T _A = 25 °C 260 mV max T _A = -40 °C ~ 70 °C |
| Turn ON time (measured from Input Signal) | 3 msec max Both Poles turn-on together |
| Turn OFF time (measured from Input Signal) | 50 μsec max Both Poles turn-off together |
| Time Difference at Turn-on between Poles | 20 μsec max |
| Time Difference at Turn-off between Poles | 20 μsec max |
| Min Trip current (Each Pole) | 8.8A DC 8.8A AC RMS |
| Trip time | |
| 12A | 320 msec ~ 846 msec |
| 20A | 130 msec ~ 270msec |
| 50A | 22 msec ~ 42 msec |
| 90A | 7 msec ~ 13 msec |
| 100A and above | Less than 3 μsec |
| Repetitive Fault current Rating | 250A |
| Output Rise Time (turn ON) | 5 μsec typ |
| Output Fall Time under normal turn-off | 300 nsec typ |
| Output Fall Time under Fault | 300 nsec typ |
| Min Load Requirement | Nil |

| Protection | |
|--------------------------|-----------|
| Short Circuit Protection | Upto 250A |

Datasheet 4119, Rev. C.1

| | |
|---|--|
| Voltage Spikes | External Transient Voltage Suppressor to handle short-circuit turn-off spike |
| OTP (Over Temperature Protection) threshold | typ. 75 °C, min. 70 °C, max 80 °C |
| OTP response time | typ. 5 sec |

Physical Characteristics

| | |
|-----------------------|---------------------------------|
| Temperature | |
| Operating Temperature | T _A = -40°C to +65°C |
| Storage Temperature | T _A = -55°C to +85°C |

| | |
|-------------------------------|---|
| Environmental | |
| Altitude | Upto 30,000 ft Can be installed in an unpressurized area |
| Case Dimensions | 2.8"L x 1.15"W x 1.15"H |
| Operating Orientation | Any |
| Weight | 60 grams typ |
| MTBF (Estimate: MIL STD 217F) | 100,000 hrs at 25°C Full load |

Mechanical Dimensions (in Inches)

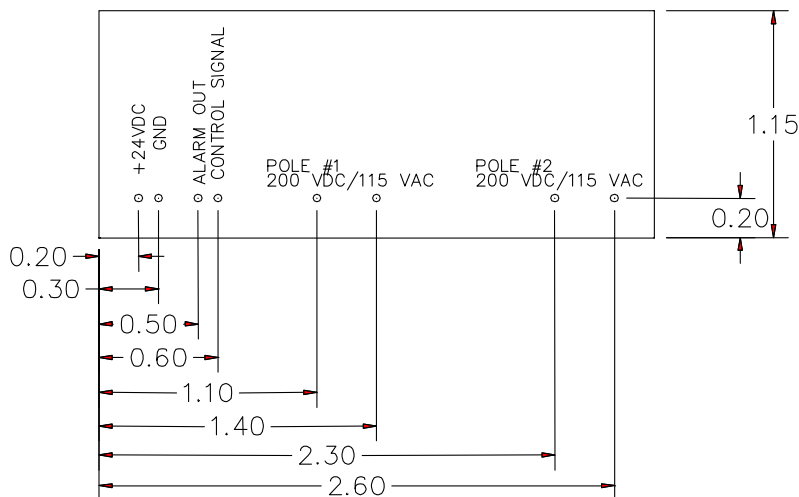
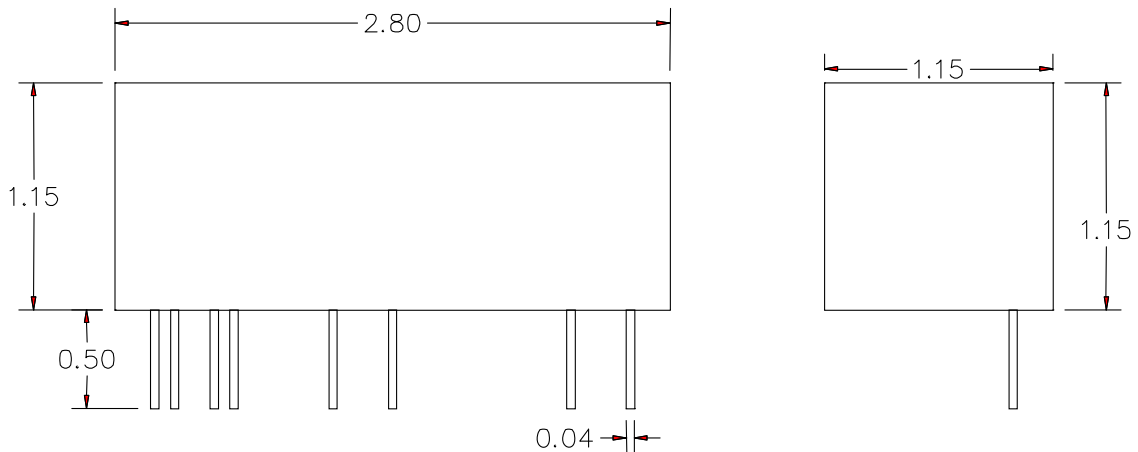

DISCLAIMER:

1- *The information given herein, including the specifications and dimensions, is subject to change without prior notice to improve product characteristics. Before ordering, purchasers are advised to contact the Sensitron Semiconductor sales department for the latest version of the datasheet(s).*

2- *In cases where extremely high reliability is required (such as use in nuclear power control, aerospace and aviation, traffic equipment, medical equipment, and safety equipment), safety should be ensured by using semiconductor devices that feature assured safety or by means of users' fail-safe precautions or other arrangement.*

3- *In no event shall Sensitron Semiconductor be liable for any damages that may result from an accident or any other cause during operation of the user's units according to the datasheet(s). Sensitron Semiconductor assumes no responsibility for any intellectual property claims or any other problems that may result from applications of information, products or circuits described in the datasheets.*

4- *In no event shall Sensitron Semiconductor be liable for any failure in a semiconductor device or any secondary damage resulting from use at a value exceeding the absolute maximum rating.*

5- *No license is granted by the datasheet(s) under any patents or other rights of any third party or Sensitron Semiconductor.*

6- *The datasheet(s) may not be reproduced or duplicated, in any form, in whole or part, without the expressed written permission of Sensitron Semiconductor.*

7- *The products (technologies) described in the datasheet(s) are not to be provided to any party whose purpose in their application will hinder maintenance of international peace and safety nor are they to be applied to that purpose by their direct purchasers or any third party. When exporting these products (technologies), the necessary procedures are to be taken in accordance with related laws and regulations.*